

Flap Barrier Installation Guide

Applicable Models: FBL 1000 / 2000

Version: 1.0 Date: Nov. 2016

Test Procedure

Connect cables to the devices and supply the input power of AC 100-120V / 200-240V (Note that a ground cable must be connected).

- ① Start the air switch and wait 10 seconds till the flap barrier completes the self-test procedure.
- ② Check the flap barrier and the LED indicators functions. If all function properly, then start the civil installation. If an exception occurs, contact your sales agent.

2.1 Device Installation Conditions and Installation Position

Ensure that expansion screws can be fastened securely in a concrete structure. If the ground foundation does not meet this condition, consult professional building or decoration personnel. Create stable conditions for reliably fastening the flap barrier, for example, drive piles or lay out steel plates.

Determine to build one or multiple passages.

When a flap barrier is installed against the wall, it need reserve 100 mm space. The space is used to open the upper cover of the flap barrier for maintenance and commissioning. The master machine and slave machine of the FBL 1000 flap barrier can form a passage. They can be installed to form dual passages with one FBL 1200 flap barrier also, as shown in Figure 2-1. The unit of data in the figures is mm.

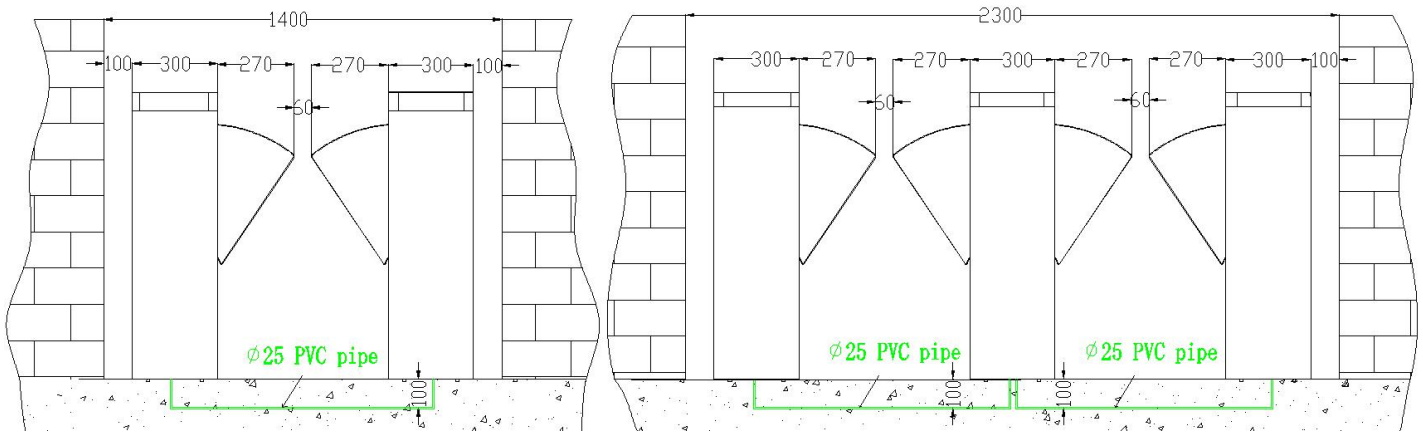

Figure 2-1

The master machine and slave machine of the FBL 2000 flap barrier can form a passage. They can be installed to form dual passages with one FBL 2200 flap barrier also, as shown in Figure 2-2.

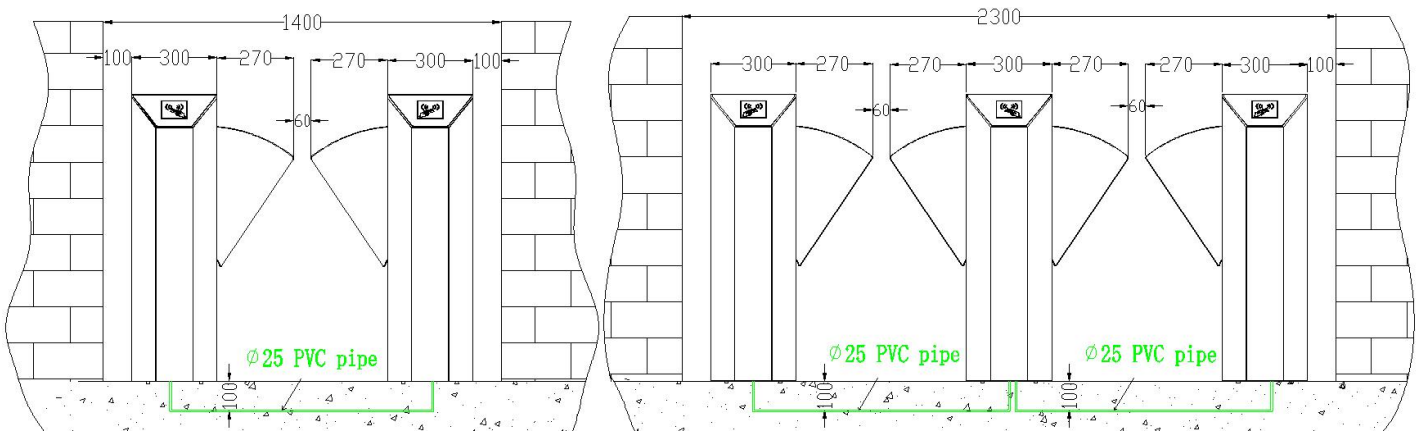

Figure 2-2

2.2 Cable Installation

For the outlet of concealed cables, see the installation hole positions of the flap barrier in Figure 2-3. The device uses 6 x 1.5 mm² cables with the voltage input range of AC 100-240 V as the power supply cable (including ground cables).

Only professional electricians are allowed to wire the flap barrier and a ground cable must be connected for the flap barrier. A dedicated ground cable binding post is provided on the inner bottom side of the chassis. Ensure that the ground cable at the far end is grounded reliably. Note that the PVC conduits should be buried under the ground for more than 60mm, and the part exposed above the ground should exceed 50mm. In addition, the conduit outlet must be bent to prevent water from entering the conduit.

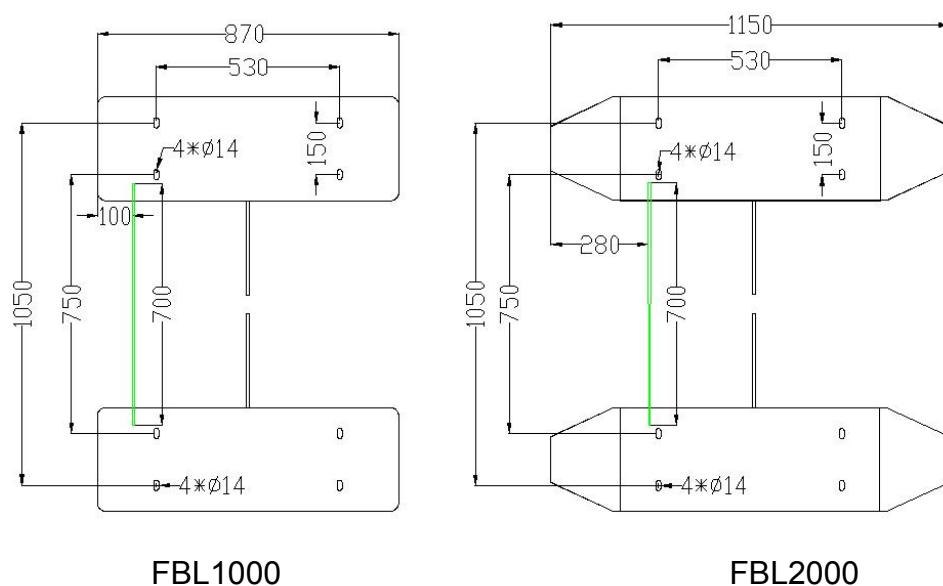

Figure 2-3

2.3 Device fixing and Installation

Procedure

- ① Power on the master machine and slave machine, adjust the wing arms. Ensure that the wing arms are in the same line and the distance between the wings is 60 mm. Make the wings to be in the OFF state.
- ② Make sure the infrared correlation tubes on both sides align with each other.
- ③ Make marks: Mark the screw hole centers of the base and chassis base edges on the ground.
- ④ Drill holes: Move away the chassis and get ready a hammer drill and a 14 mm drill bit. Drill a hole with the depth of 80 mm in the screw hole center marks. Alternatively, drill holes according to installation hole positions. For devices, see Figure 2-3 for installation hole positions. The unit of data in the figures is mm.
- ⑤ Apply screw glue to the outer surface and threads of the expansion screws, insert expansion screws, and fix the master machine and slave machine in the marked positions. Use a level checker (or spirit level) to check whether the installation ground foundation is in correct level. If not, use a pad for adjustment.

Note: It is recommended that a canopy be set up out of door. And it is recommended to set guard lines to prompt the users to swipe cards outside the guard lines.

Connection Cables between the Master Chassis and the Slave Chassis

Two 6-core connection cables are deployed between two flap barriers. And the circuit wiring is shown in figure 3-1.

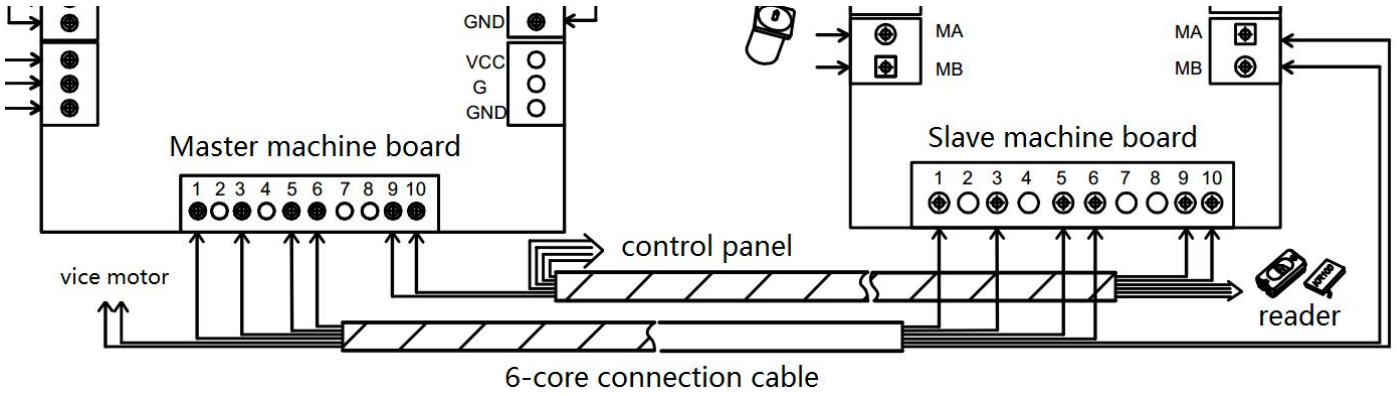

Figure 3-1

Chapter 4 The Operation of the Menu

4.1 Buttons specification

MENU: to enter menu interface.

UP: to move up a menu item or increase the value.

DOWN: to move down a menu item or reduce the value.

OK: to enter the menu setting item or confirm the current changed value.

CANCEL: to return to the previous menu or to cancel the current operation.

4.2 The operation of the menu

User can press "MENU" button, enter the password and then press "OK" to enter the menu interface. If any step fails, the user can press the "CANCEL" button to get back.

The default password is "UP, UP, DOWN, DOWN, DOWN, DOWN".

After entering the menu, user can press "UP" or "DOWN" to choose a menu item and then press "OK" to enter the interface and change function or value.

Chapter 5 Product Maintenance

- ① Non-professional personnel are not allowed to open the chassis and perform tests, maintenance, or repairing on the product.
- ② The chassis is made of semi-gloss stainless steel. The chassis surface should be cleaned frequently with a soft silk fabric. Do not use a hard article to wipe the surface to avoid scratches. Water flushing is strictly forbidden so as to avoid water from entering the product, which may result in short circuit of the electronic control system.
- ③ Each movable part of the product should be checked on a regular basis to prevent loosening of fasteners; otherwise the barrier may fail after long-time operation.
- ④ Apply lubricating oil to the movable points and the connecting points on a regular basis.
- ⑤ Check the circuit connectors and wiring points on a regular basis to ensure reliable connection.
- ⑥ Check on a regular basis whether the system's protective earth wire is reliably connected.
- ⑦ After repairing or maintaining the product, close the circuit board protection cover and the chassis door.